

# DIRT TRAP DT 100

*For Dirt & Moisture Mitigation*

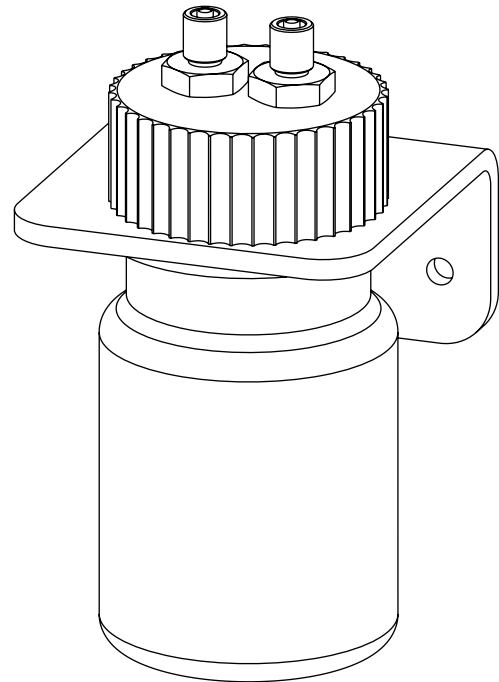

## FEATURES

- Compact design
- Removable 100 ml glass vessel
- Fittings for 4x6 mm or 3x5 mm FEP tubing

## APPLICATIONS

- Detecting presence of condensate and dirt
- For use with BMT 964/965 gas analysers

The DIRT TRAP DT 100 is an ozone-resistant washing bottle, which can be used when higher quantities of fluids may be expected to occasionally appear in the sample gas. The DT 100 may retain and store these fluids, and particulates, too.

For continues cooling and drying ozone sample gas, we recommend to use the sample gas dryer DH6.

Dimensions:

